

Zubehör:
WireLane Adapter

Accessories:
WireLane Adapter

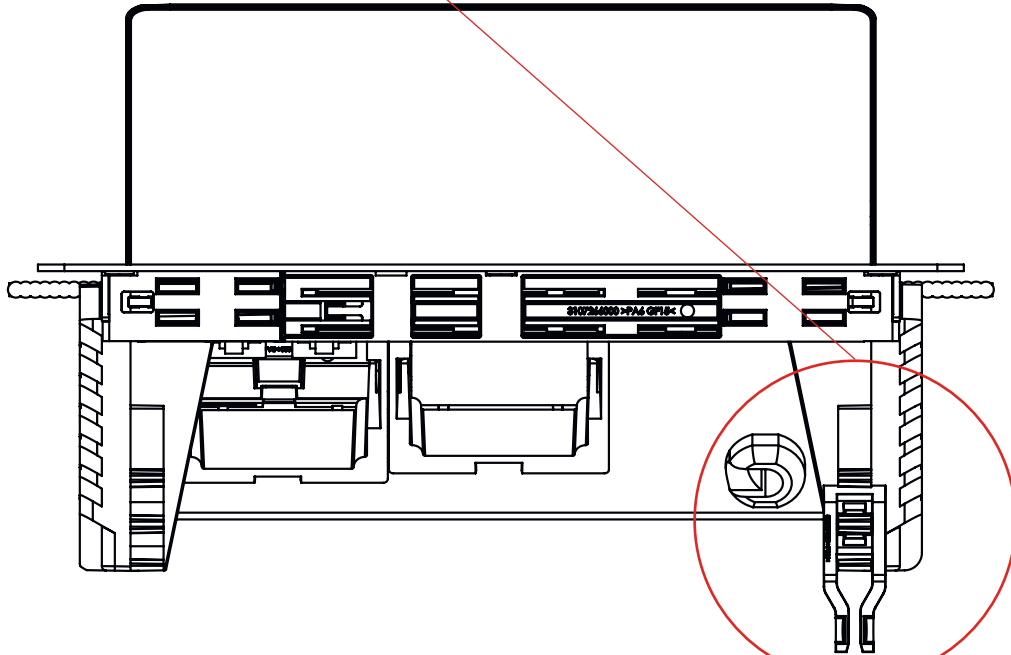

Schulte Elektrotechnik GmbH & Co. KG

Jüngerstraße 21
D-58515 Lüdenscheid

Telefon +49 23 51 / 94 81-0
Telefax +49 23 51 / 4 26 58

Email info@schulte.com
Alle weiteren Produkte aus
unserem Sortiment finden
Sie unter:
www.evoline.com

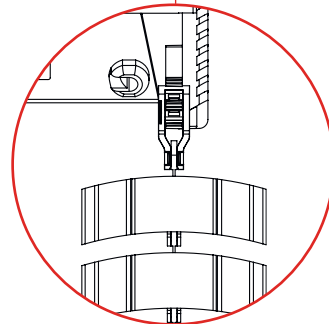
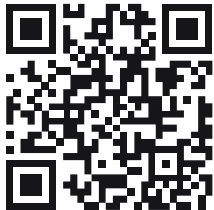

EVoline FlipTop Push



Lieferumfang / Delivery includes:

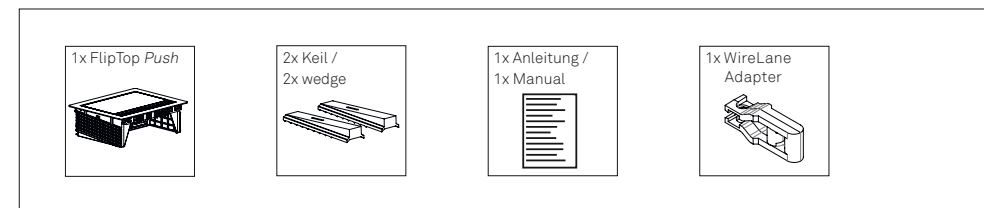

Funktionserläuterung

Vor Gebrauch bitte beachten:
Öffnet sich durch einfaches Antippen
des Deckels (Soft Touch)

Functional description

Please read instructions before use
Opens by simply tipping the cover
(soft touch)

Montageanleitung / Vorbereitung

Der EVoline® FlipTop Push
kann in Plattenstärken von
10 bis 50 mm eingebaut werden.
Der Lochausschnitt muss mit einem
Mindestabstand von 100 mm zur
Plattenkante platziert werden.

Mounting instructions / Preparation

The EVoline® FlipTop Push can be
mounted in desk plates from
10 up to 50 mm thickness.
The cut-out must have a minimum
distance of 100 mm from the plate
edges.

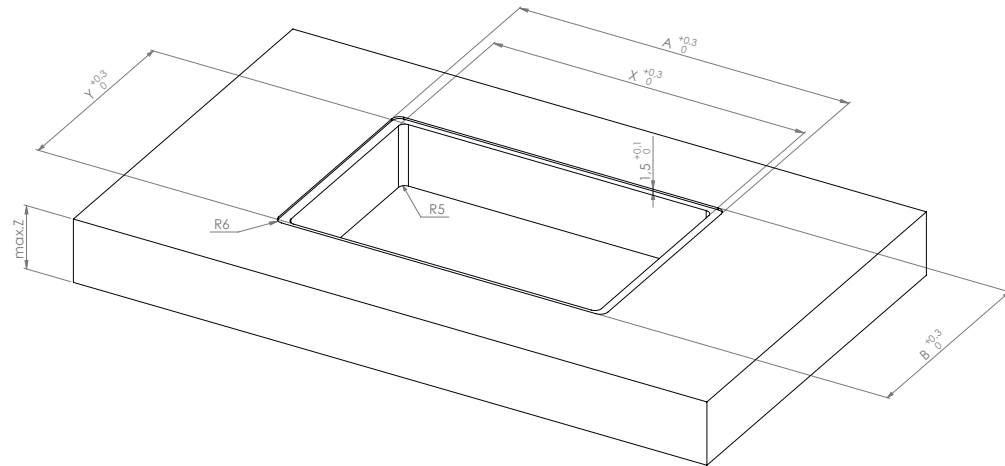

XL	360 mm	167 mm	345 mm	157 mm	max. 50 mm
L	310 mm	167 mm	295 mm	157 mm	max. 50 mm
M	260 mm	167 mm	245 mm	157 mm	max. 50 mm
S	210 mm	167 mm	195 mm	157 mm	max. 50 mm
Ausführung model	A	B	X	Y	Z
	Flächenbündiger Einbau flush installation		Normaler Einbau normal installation		

Bitte bei einer Plattenstärke
von über 40 mm beachten!

Please note for desk plates with
a thickness from more than 40 mm!

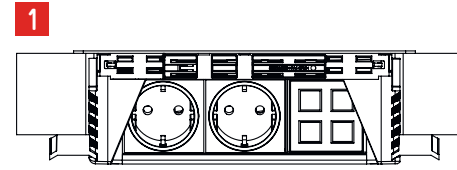
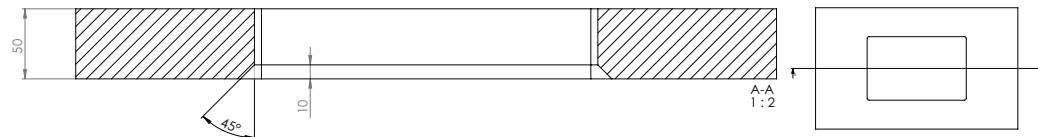

Produkt im
Tischausschnitt
positionieren

Place product
in cutout

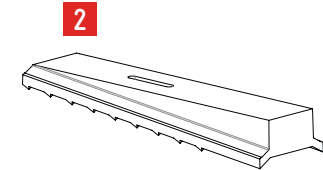

Fixierkeil

Fixing wedge

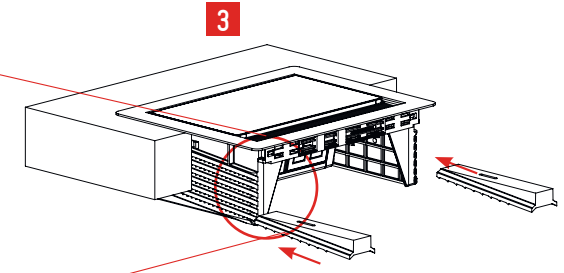
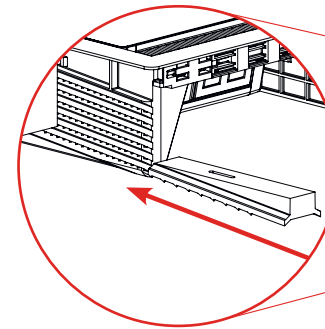

Beide Fixierkeile
bis zum Rastpunkt
einschieben.

Slide in both
wedges until
locked.

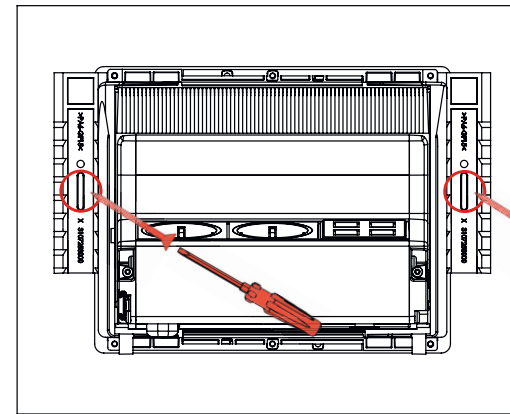

Zusätzliche
Fixierung durch
2 Schrauben

Additional fixing with
2 screws

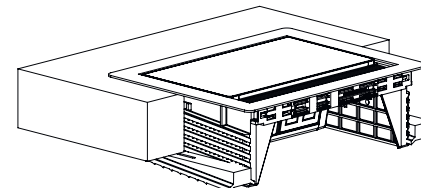

Bitte ziehen
Sie nach
abgeschlossener
Montage die
Schutzfolie ab.

After assembly
please remove
protective foil.

